

VACUUM APPLICATIONS

**XR-100
X-123**

Vacuum Operation

The XR-100 can be operated in air or in vacuum down to 10^{-7} Torr. There are four ways the XR-100 can be operated in vacuum.

Down to 10^{-7} Torr

Option A: The entire XR-100 detector and preamplifier box can be placed inside the chamber. In order to avoid overheating and dissipate the 1 Watt of power needed to operate the XR-100, good heat conduction to the chamber walls should be provided by using the four mounting holes. An optional Model 9DVF 9-Pin D vacuum feedthrough connector on a Conflat is available to connect the XR-100 to the PX5 or PX2 outside the vacuum chamber.

Option B: The XR-100 can be located outside the vacuum chamber to detect X-Rays inside the chamber through a standard Conflat compression O-ring port. Optional Model EXV9 (9 inch) or EXV5 (5 inch) vacuum detector extender is available for this application.

Below 10^{-7} Torr

Option C: Only available with the FAST SDD™ detector, this configuration places only the detector in the chamber. Custom UHV cables, connectors, and a 15-Pin D flange are used to connect to the preamplifier and processor which are on the outside of the chamber.

Option D: Ultra High Vacuum with FAST SDD and manual Linear Adjustment (100 mm).

Other motorized or manual Linear Adjustments are available.

Option A: Detector and preamplifier in the chamber

Option A-1: XR-100 with PX5

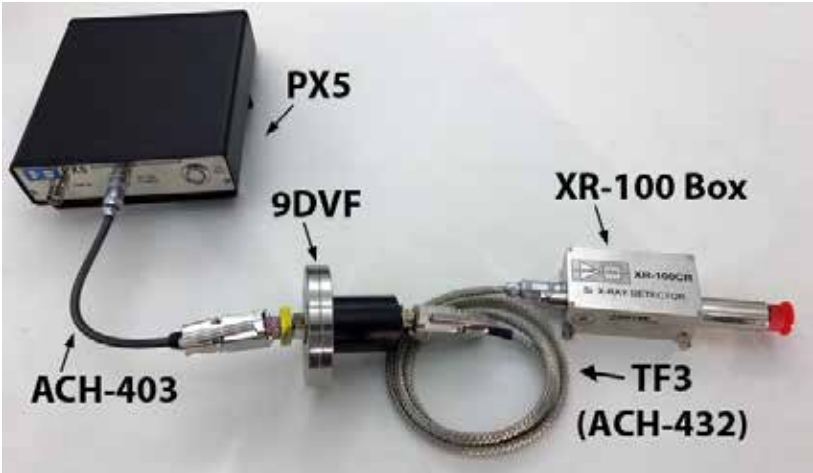

Figure 1. Option A-1 with PX5

Required items for XR-100 with PX5

- XR-100CR, XR-100SDD, or XR-100T-CdTe
- TF3 Power Cable (ACH-432, 6-pin lemo to 9 pin D)
- 9DVF Feedthrough connector
- PX5 (includes ACH-403 Cable and ACH-442 Gender Changer)
- NOTE: No signal cable is included from the XR100 to the vacuum wall. This is the responsibility of the user. A standard BNC cable is provided for use outside of the chamber

OEM's #1 Choice

Option A: Detector and preamplifier in the chamber (con't)

Option A-2: AXR/PA-230 or PA-210 with X-123

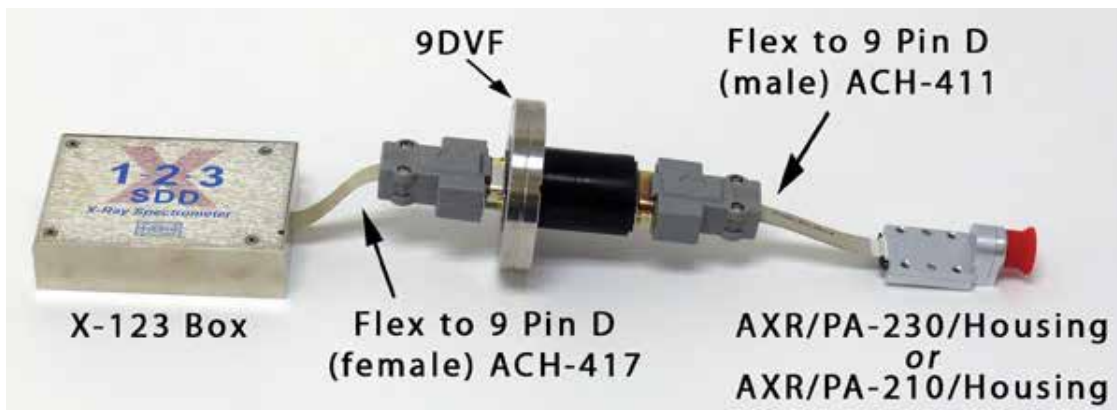

Figure 2. Option A-2 with X-123

Required items for AXR/PA-230 or PA-210 with X-123

- AXR Detector (Si-PIN, SDD, or CdTe)
- PA-210 or PA-230 preamplifier
- PA-210 or PA-230 housing
- 9DVF Feedthrough connector
- Flex to 9 Pin D (male) cable (ACH-411)
- Flex to 9 Pin D (female) cable (ACH-417)
- X-123 Digital Pulse Processor and Power Supply

Quad Configuration



Figure 3. Option A-2 Quad Configuration

Quad Configuration of SDDs with PA230 preamplifiers for vacuum applications. To complete the system four X-123 SDDs are required.

Option B: Detector on an extender through a port



Figure 4. X-123 X-Ray Spectrometer and XR-100, each shown with the EXV9 extender and CP75 vacuum feedthrough coupling.



Figure 5. Amptek detector with PA-230 preamp, housing, EXV9 extender and CP75 vacuum feedthrough coupling

Option B-1: XR-100 with PX5

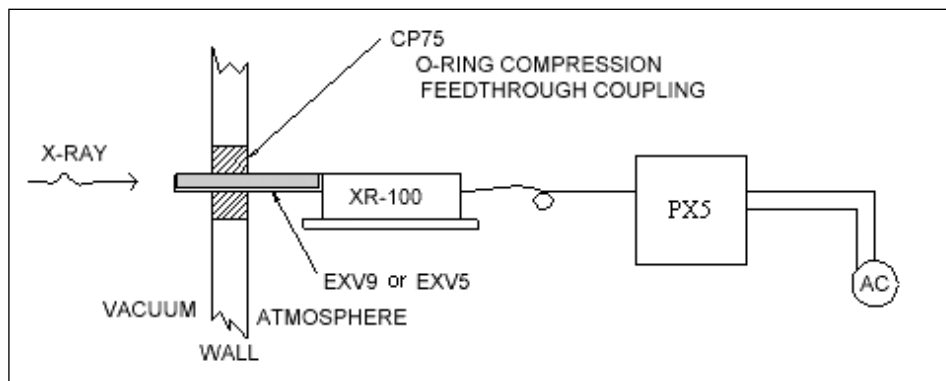

Figure 6. Diagram of XR-100 with PX5 set-up in vacuum

Option B-1 Required Items for XR-100/PX5

- XR-100CR, XR-100SDD (or FAST SDD), or XR-100T-CdTe
- EXV9 or EXV5
- CP75 Feedthrough coupling
- PX5 Digital Pulse Processor and Power Supply

Option B: Detector on an extender through a port (con't)

Option B-2: X-123

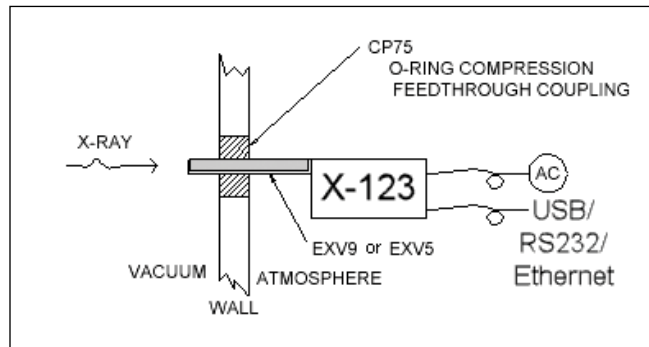

Figure 7. Diagram of X-123 set-up in vacuum

Option B-2 Required Items for X-123

- X-123 Si-PIN, X-123 SDD (or FAST SDD), or X-123 CdTe
- EXV9 or EXV5
- CP75 Feedthrough coupling

Option C (FAST SDD Only): Ultra High Vacuum (UHV)

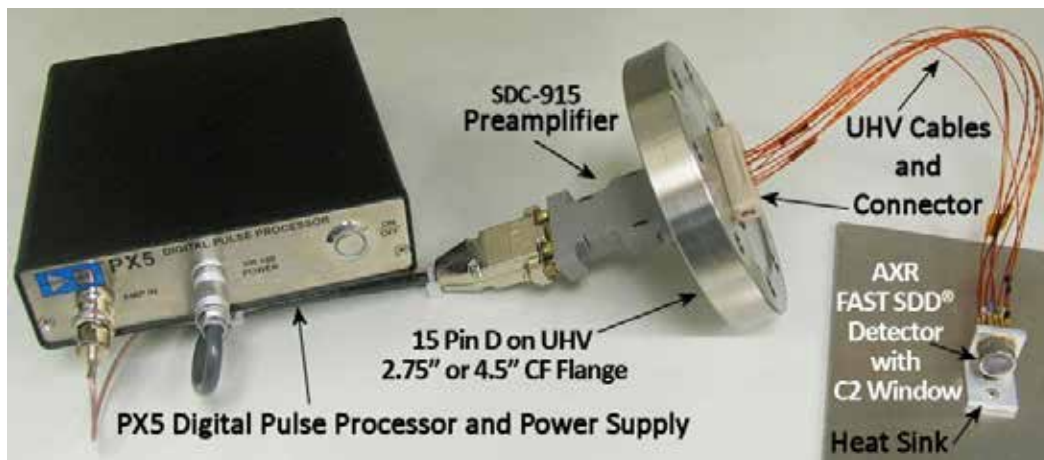

Figure 8. Ultra High Vacuum configuration with PX5 and FAST SDD

Option C Required Items

- FAST SDD detector with right angle heat sink
- UHV cables and connector from detector to flange
- 15-Pin D on UHV 2.75" or 4.5" CF Flange
- SDC-915 Preamplifier
- Cables from flange to PX5
- PX5 Digital Pulse Processor and Power Supply

Option D: Ultra High Vacuum with FAST SDD and manual Linear Adjustment

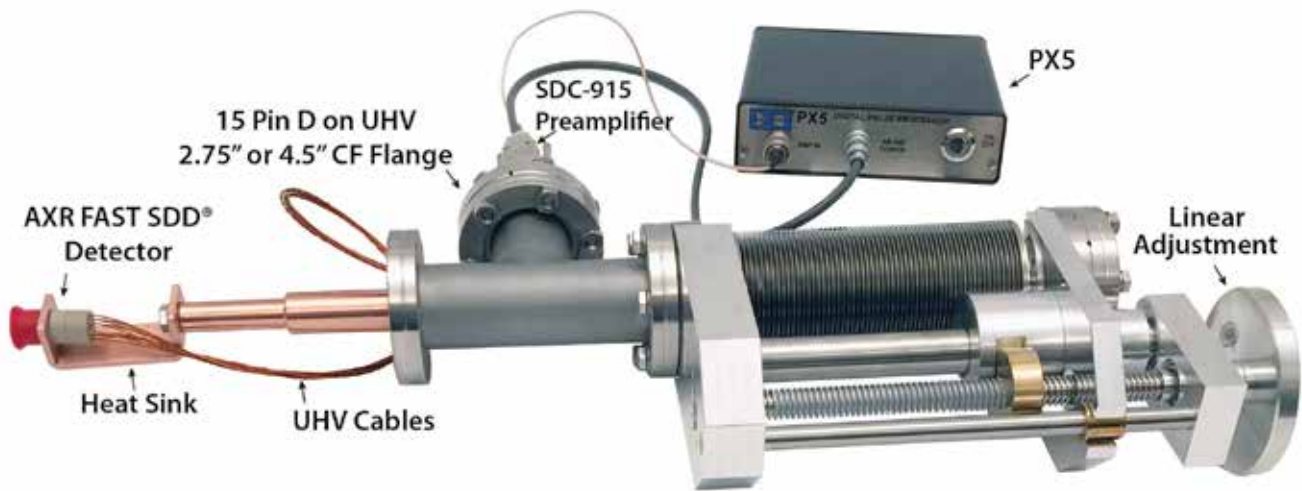

Figure 9. Ultra High Vacuum configuration with PX5 and FAST SDD and manual Linear Adjustment (100 mm). Other motorized or manual Linear Adjustments are available.

Option D Required Items

- FAST SDD detector with 100 mm Linear Adjustment and heat sink
- UHV cables and connector from detector to flange
- 15-Pin D on UHV 2.75" or 4.5" CF Flange
- SDC-915 Preamplifier
- Cables from flange to PX5
- PX5 Digital Pulse Processor and Power Supply

Vacuum Accessories

MODEL 9DVF

9 pin D-subminiature vacuum feedthrough connector mounted on a standard 2 3/4" stainless steel Conflat.

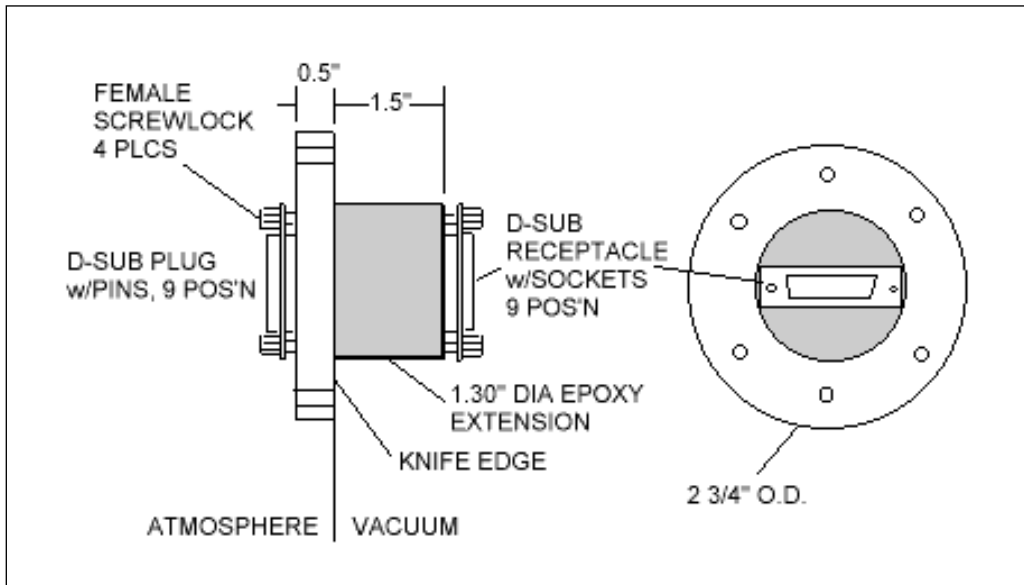

Figure 10. All dimensions are in inches except as noted.

EXV9 - 9" Vacuum Extender

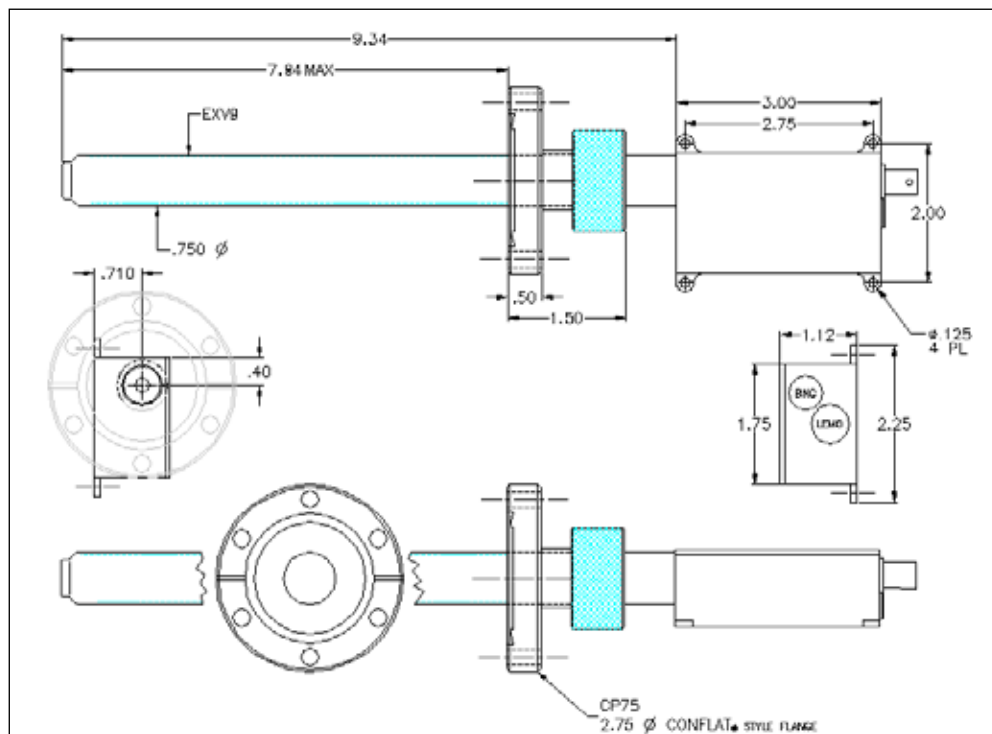

Figure 11. EXV9 - 9" vacuum extender shown with CP75. All dimensions are in inches except as noted.

Vacuum Accessories (con't)

EXV5 - 5" Vacuum Extender

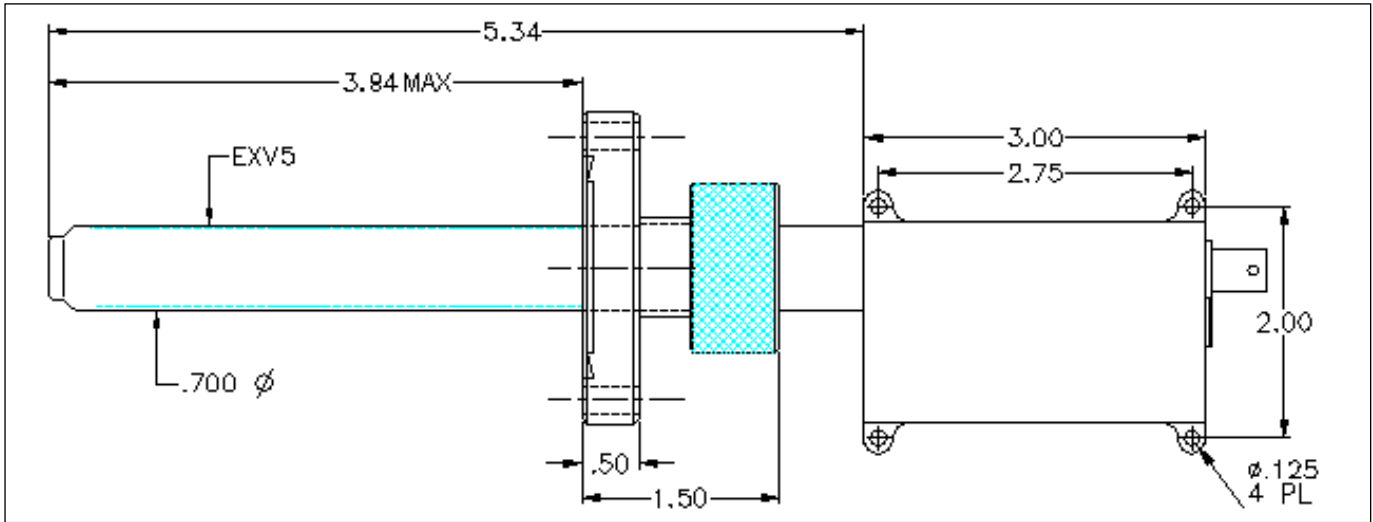

Figure 12. EXV5 - 5" vacuum extender shown with CP75. All dimensions are in inches except as noted.

MODEL CP75

Vacuum feedthrough coupling on 2 3/4" Conflat for use with the EXV9 or EXV5.

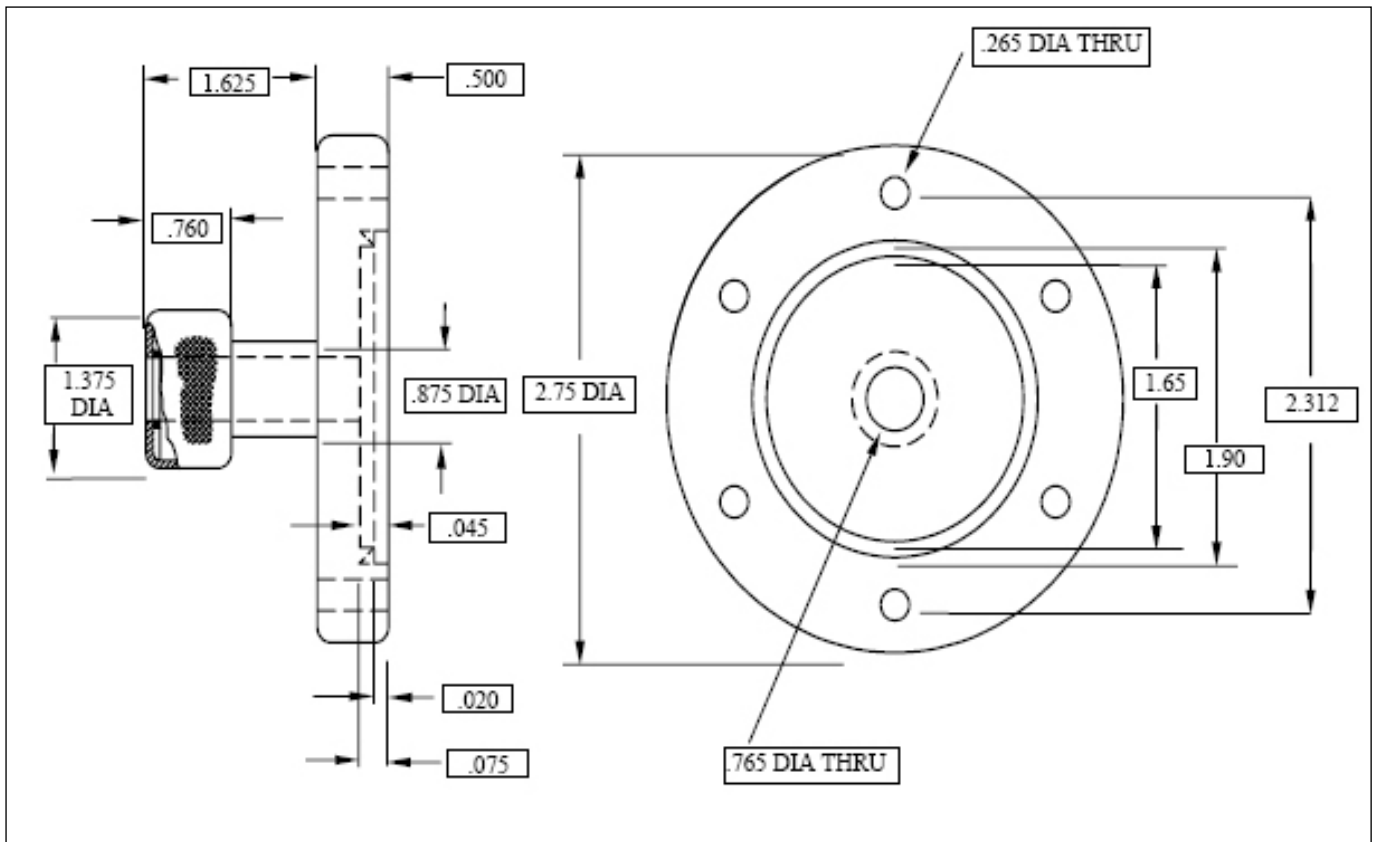

Figure 13. All dimensions are in inches except as noted.

Vacuum Accessories (con't)

EXVC COLLIMATOR KIT for the EXV9

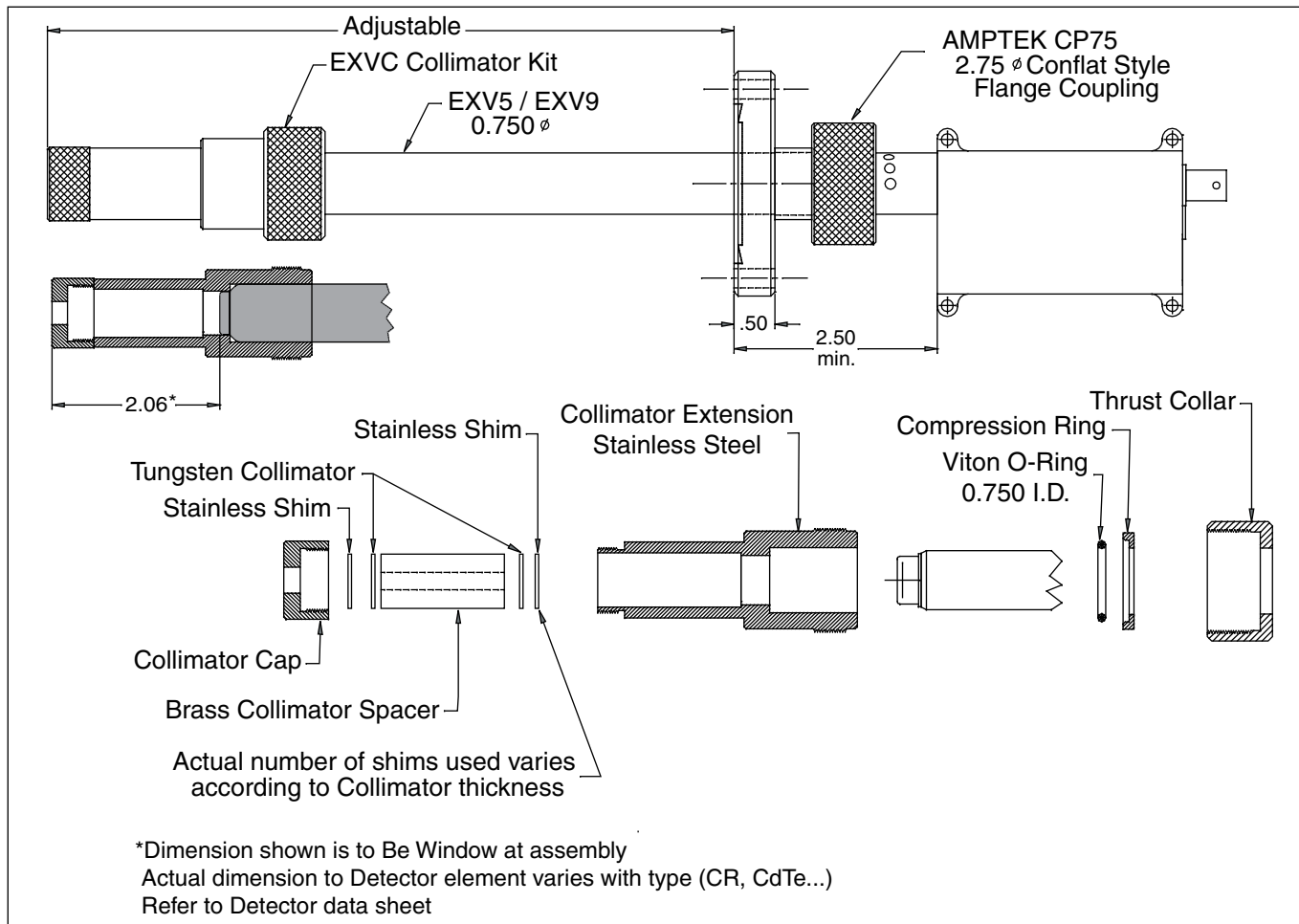
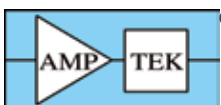

Figure 9. All dimensions are in inches except as noted.

The EXVC - Collimator Kit Includes:

- Stainless steel collimator housing
- Brass Spacer
- Tripod and mounting plate (included when ordering for use with standard 1.5 inch extender box)
- Laser pointer
- 7 Tungsten (W) Collimator disks:
 - 1 mm thick with 25 μm hole
 - 1 mm thick with 50 μm hole
 - 2 mm thick with 100 μm hole
 - 2 mm thick with 200 μm hole
 - 2 mm thick with 400 μm hole
 - 2 mm thick with 1000 μm hole
 - 2 mm thick with 2000 μm hole
- Optional: EXVC-W-SPACER
 This Tungsten (W) Spacer /Collimator is 35 mm thick with a 350 μm hole. It is designed to stop and collimate x-rays greater than 100 keV produced from high energy tubes.

All Tungsten disks are made of alloy HD17 (90% W, 6% Ni, 4% Cu).



AMPTEK INC. 14 DeAngelo Drive, Bedford, MA 01730-2204 USA

+1 781 275-2242 Fax: +1 781 275-3470 sales@amptek.com www.amptek.com

AMETEK
MATERIALS ANALYSIS DIVISION